

APPLICATION

Controllable current amplifier type 30RE11 serves to control 2-position proportional hydraulic directional valves type USEB 6 with position sensor. Amplifier type 32RE11 serves to control 2-position proportional directional valves type USEB10 with position sensor.

Main characteristics:

- output current control
- high stability of output current due to feedback loop at end stapes
- adjustment of pulse rise and decay time
- system for quick transition through zero
- generator 2,5 kHz and demodulator at supply of offset sensor
- board construction to Eurocard
- joint type 811064 at output
 - from internal programmer
 - by external voltage +/- 9V towards mass
 - by external voltage 0 up to 10V non-potential

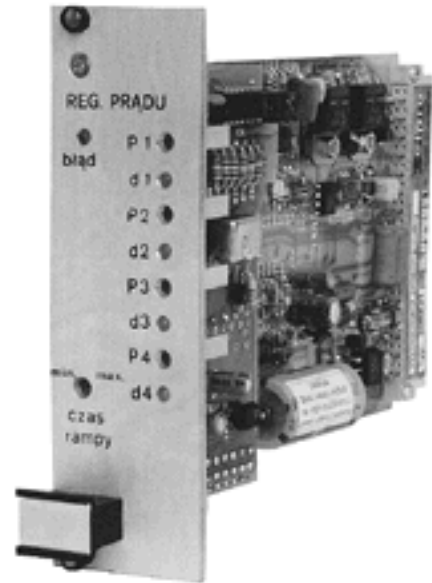

DESCRIPTION OF OPERATION

d1 ÷ d4 - signaling of set value feeding

d5 - signaling of break in supply of offset detector

P1 ÷ P4 - adjustment of programmable set values

PR7 - adjustment of pulse rise out decay time 0,05-5s

W1 ÷ W4 - unstable switches of set value

W5 - stable switch of pulse rise and decay time

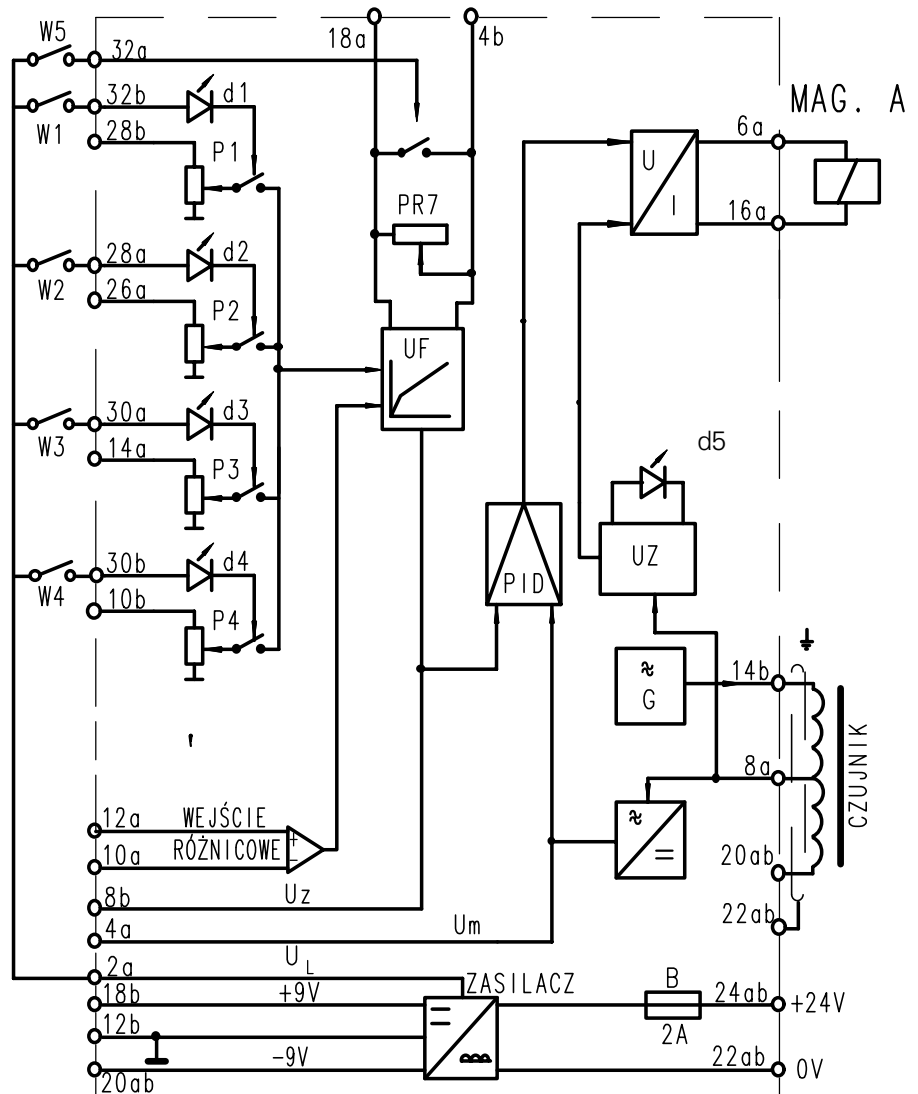

DESCRIPTION OF OPERATION

Controllable current amplifier type **30RE11 (32RE11)** must be supplied with the voltage **24V** full waved rectified to contacts: pole **/+ /** to contact **24ab**; **/0 /** to contact **22ab**. From supply voltage via constant-voltage regulator stabilized voltage **+/- 9V** at contacts: **18b (+9V)**; **12b (0V)**; **20ab (-9V)** is achieved. Please, take care that measurement "0" (contact **12b**) is higher by **9V** than supply voltage "0" (contact **22ab**).

The electronic keys with unstable switches **W1÷ W4** must be used to program set value. They should be correlative that is when one key is switched on then the rest keys are automatically switched off. The specified values are set by means of potentiometers **P1÷P4**, whereas switching on the key is signaled by a specified light **d1÷ d4** on the front plate.

The set value can also be sent by matching amplifier from non-potential inputs **10a (0 ÷10V)** and **12a (0V)**.

In order to program the rise and decay time of the set value at step control. The potentiometer **PR7** is applied.

It is possible to break this adjustment by means of the switch **W5**.

An additional change - over switch can be connected to terminals **18a** and **4b**, or the contacts of a transmitter permitting a ramp shorting independently of the switch **W5**. In case of need to set times of the ramp beyond the plate, an additional potentiometer can be connected to terminals **18a** and **4b** (**PR7** set at maximum). The switch **W5** must be independent and stable. The amplifier has also a system for error signaling, which controls voltage from the offset detector and in case of break interlocks the end stages. At the same time the diode **d5** lights.

Controllable current amplifier type **30RE11 (32RE11)** should be connected to directional valves and control switches in accordance with block diagram. Lines to directional valves should not be connected together with lines of control signals. The amplifier can be connected only dead. To measure the set and real values a meter can be connected to contacts: **12b** – measurement "0"; **8b** - set value and **4a** - real value correspondingly.

Hydraulic directional valve type **USEB6 (USEB10)** is equipped with proportional solenoid, which should be connected to terminals **6a, 16a**.

The inductive position sensor has three marked terminals. Terminal **1** should be linked to **8a**; terminal **2** to **20ab** and terminal **3** (ground mark) to **14b**.

Each connection should be done by means of 3-conductor cable with a shield connected to **22ab**.

TECHNICAL DATA

Supply voltage (full waved rectified/unstabilized)	24 V +/-10%	
Power	30RE11	35VA
	32RE11	45VA
Max output current	30RE11	1,6 A
	32RE11	2,2 A
Control voltage	0 up to 10 V	
Generator frequency	2,5 kHz	
Sensor connecting (cable length)	max 30 m at 100 pF/m	
Solenoid connecting (cable length)	1,5mm ² up to 40m	
	2,5mm ² up to 60m	
Operating temperature	0 - 50 °C	
Temperature error	0,05 %/ °C	
Hysteresis	1,5 %	
Weight	0,3 kg	

OVERALL DIMENSIONS

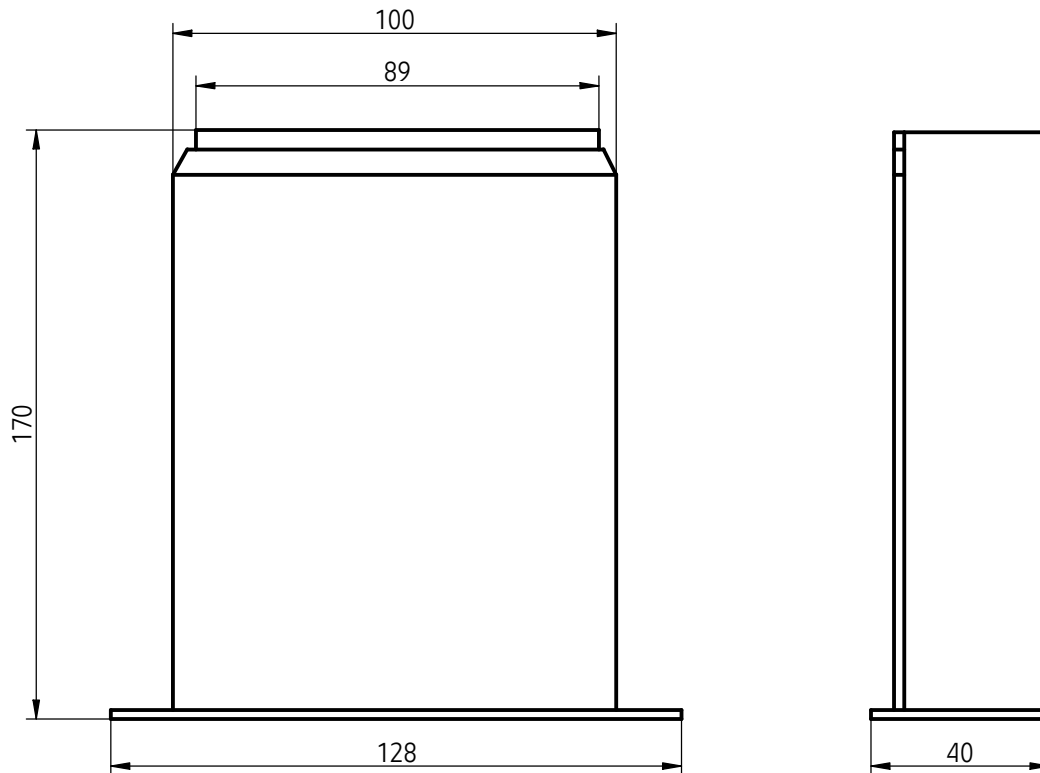

HOW TO ORDER

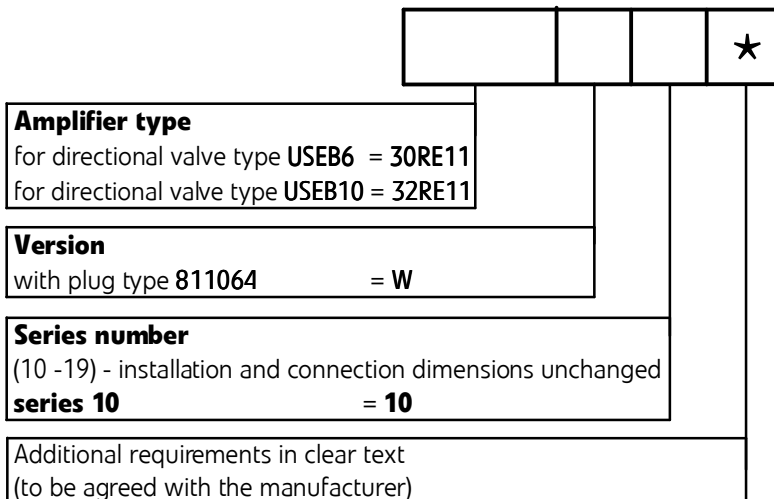

NOTES:

The amplifier should be ordered according to the above coding.
 Coding example: 30RE11 W 10

PONAR Wadowice S.A.
ul. Wojska Polskiego 29
34-100 Wadowice
tel. +48 33 488 29 00
fax. +48 33 488 21 03
www.ponar-wadowice.pl

